

Truss Bridge Competition: Load Test 14 December 2011

Objective: Build a truss bridge from **BALSA WOOD** to carry the largest load to weight ratio. Only balsa wood & approved glue (see below) may be used. Bridge must fall within dimensions & weight guidelines specified below. Attention to detail wins this contest!

Design criteria: The bridge must span a 40 cm opening. The height can be variable up to 15 cm maximum. The width can be variable from 6 cm minimum to 12 cm maximum. The top center of the truss must have a flat area for loading with 6 cm minimum length. The bridge will span a space 40 cm long, so the bridge must be slightly longer to bear on the test platform. The bridge must weigh 0.3 pound [0.14 kg] or less (previous winners weighed from 0.05 to 0.15 pound). You may weigh a bridge on a scale at the post office or the produce section of a grocery store.

Guidelines: Truss structures distribute the load across all members nearly equally. This provides for the strongest structure that weighs the least. The object is to review & sketch designs that work well and then build it. Several test bridges may be needed to get the best design. Materials can be purchased from hobby stores. The balsa comes in various dimensions (such as 1/4" by 1/4") and 24, 36 or 48 inch lengths so that little cutting is needed. Use standard white glue (Elmer's) or wood glue that is non-odorous and non-toxic (water wash-up). Be careful not to overuse the glue since it is **heavy** compared to the wood. **Any bridge using materials other than balsa or approved glue will be DISQUALIFIED!**

Testing & Scoring Criteria: The load will be applied on the top of the structure at the center of the bridge. The bridge will be loaded with a flat wooden beam driven by air pressure, starting with about 5 pounds and increasing by increments until failure. A bridge deflecting more than 1" downward will be assumed to have failed. The bridge with the highest load to weight ratio (example: 50# load/ 0.05# bridge = ratio of 1000) **wins**.

Safety tips: Be careful when using cutting equipment. Always provide support under your material. Cut away from your body. Good lighting is a must. Also provide a cutting board so that you do not damage your kitchen table or desk. An "X-ACTO" razor knife or fine tooth saw works well for cutting small beams. Scissors or a sharp kitchen knife will do an acceptable job if you smooth surfaces to be glued with fine sandpaper.

Good luck to all of you promising structural engineers. **Testing: Tuesday 14 December 2011**
Remember this is strength to weight ratio contest: try to build a **LIGHT** strong bridge.

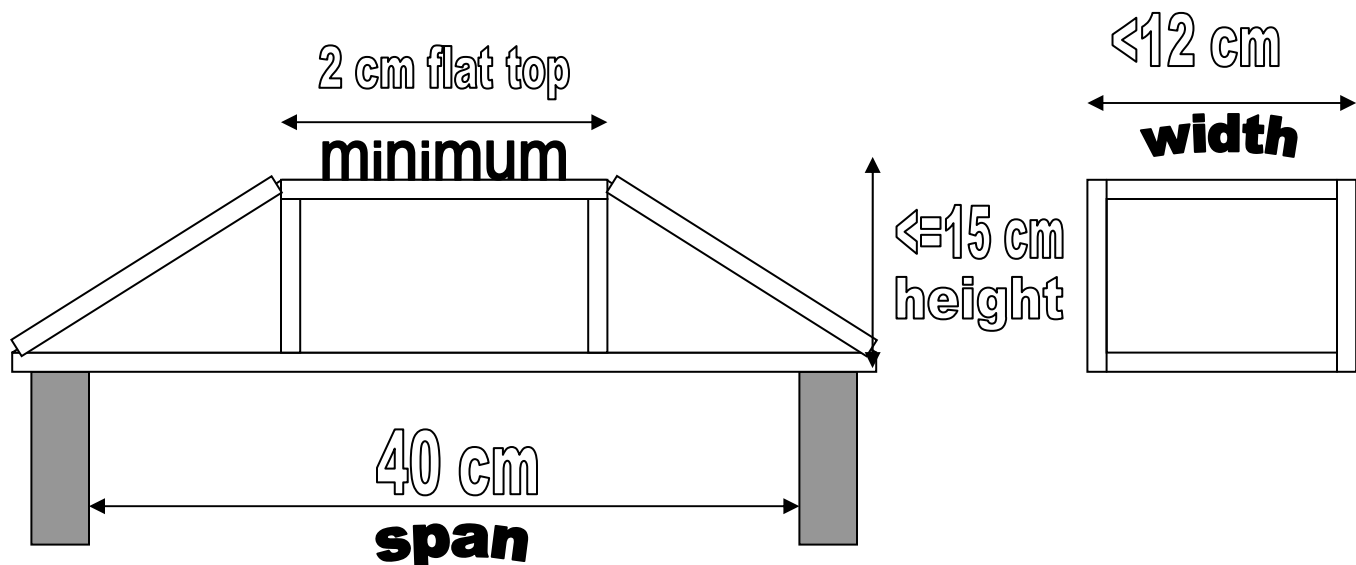

Truss Bridge Types / Styles

A truss bridge is composed of connected elements (typically straight) which may be stressed from tension, compression, or sometimes both in response to loads. Truss bridges are one of the oldest types of modern bridges. This type of bridge structure has a fairly simple design and is particularly cheap to construct owing to its efficient use of materials. Most trusses have the lower chord under tension and the upper chord under compression

Pratt Truss

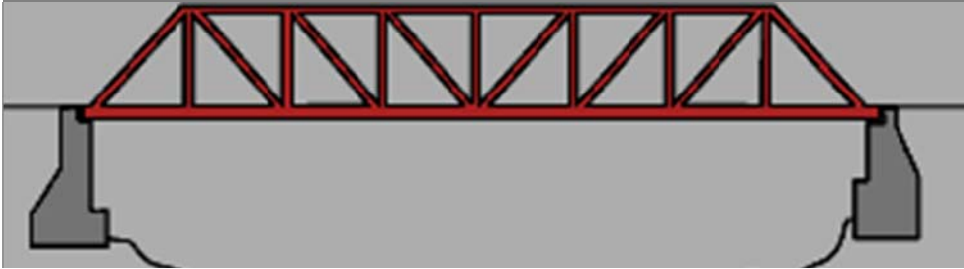

Warren Truss

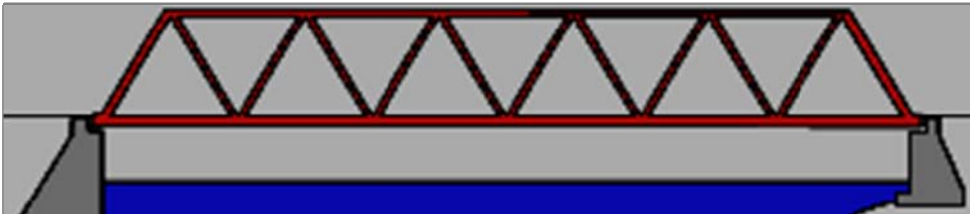

Modified Warren Deck truss

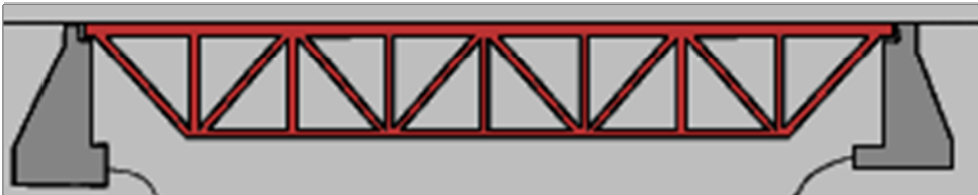

Howe truss - The Howe includes vertical members & diagonals that slope up towards the center, the opposite of the Pratt truss

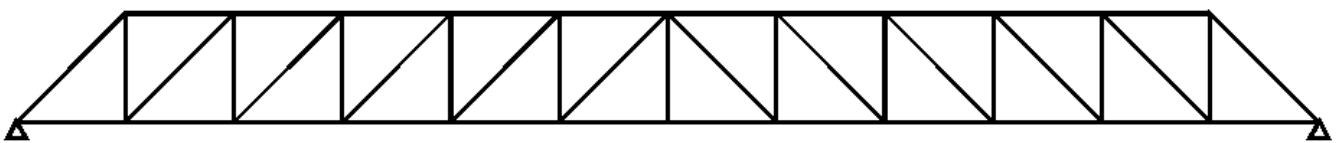

Queen Post Truss



King Post Truss



[Other Styles not pictured: \[search Wikipedia for pictures and information\]](#)

Bollman Truss
Bowstring Arch Truss
Brown Truss
Lenticular truss
Vierendeel truss

Summary of Rules:

- **Length:** longer than 40 cm. [15.75”]
- **Height:** from 1 cm to 15 cm maximum.
- **Width:** from 6 cm minimum to 12 cm maximum.
- **Weight:** 0.3 pound [4.8 ounces] [0.14 kg] maximum
- The top center of the truss must be flat for loading with 2 cm minimum length.

Additional Suggestions:

- In most years one of the **lighter bridges will win**.
- Adding “gussets” [paper or balsa acceptable] to strengthen glue joints & “X” or cross bracing to stop sidesway or buckling has been very successful
- Use as little glue as possible – wipe off any glue dripping out of joints.
- Sanding of members and glue to remove excess material can reduce weight significantly
- Precise cutting of members & sanding to get good fit-up [each piece fits flat against its neighbor] at joints is crucial. That gives you the most surface area for your glue joint.
- Practice bridge design at <http://bridgecontest.usma.edu/>
- Use Deck elevation 20 meters → 40 meter span 1:100 scale
- No pier, no cables
- Templates for Warren, Pratt & Howe trusses
- Pick direction & relative size of members
- Hobby Lobby Mon-Sat 9a-8p
2310 Matthew Township Parkway
Matthews, NC 28105
(704) 844-6609